



32-5037-04

Available in French Canadian (FC)

# User's Information Guide

## High Efficiency Oil Furnaces Highboy Vertical, Lowboy Front or Rear Flue, Downflow/Horizontal

### GENERAL INFORMATION

Understand the signal words **WARNING**, and **CAUTION**. These words are safety alert words. **WARNING** indicates hazards which **could** result in personal injury or death. **CAUTION** is used to indicate unsafe practices which could result in minor injury or property damage.

### **WARNING**

#### SAFETY HAZARD

**DO NOT USE THIS UNIT IF ANY COMPONENT HAS BEEN UNDER WATER. IMMEDIATELY CALL A QUALIFIED SERVICE TECHNICIAN TO INSPECT THE FURNACE AND TO REPLACE ANY PART OF THE CONTROL SYSTEM AND ANY GAS CONTROL WHICH HAS BEEN UNDER WATER. THIS FURNACE DOES NOT HAVE A PILOT LIGHT. IT IS EQUIPPED WITH AN ELECTRONIC IGNITION SYSTEM. FAILURE TO FOLLOW THIS WARNING MAY RESULT IN PERSONAL INJURY, PROPERTY DAMAGE, OR DEATH.**

#### IMPORTANT FACTS

The flow of combustion and ventilating air must not be obstructed from reaching the furnace. Air openings provided in the casing of the furnace must be kept free of obstructions which would restrict airflow, thereby affecting efficiency and safe operation of your furnace.

Also, air openings provided to the area in which the furnace is installed and the space around the furnace shall not be blocked or obstructed. Keep this in mind should you choose to remodel the area which contains your furnace.

The furnace and venting system require a generous amount of clean air to operate safely. Lack of adequate combustion and ventilation air can result in erratic operation of the burner, noisy and poor combustion, sooting of the combustion chamber, and fuel odors in the air. Never block off or restrict the supply of air to the furnace.

The combustion air for your furnace must be fresh uncontaminated air. Paints, varnishes, laundry bleaches, detergents, many household cleaners, water softening salts, adhesives, and all such products release fumes containing compounds which could lead to early heat exchanger and vent system deterioration. Do not store these types of products near your furnace.

**Never store gasoline, combustible materials, or other flammable liquids or vapors near your furnace.**

### **WARNING**

#### SAFETY HAZARD

**TO PREVENT AN EXPLOSION OR POSSIBLE INJURY, DEATH AND EQUIPMENT DAMAGE, DO NOT STORE COMBUSTIBLE MATERIALS, GASOLINE OR OTHER FLAMMABLE VAPORS OR LIQUIDS NEAR THE UNIT. FAILURE TO FOLLOW THIS WARNING MAY RESULT IN PERSONAL INJURY, PROPERTY DAMAGE, OR DEATH.**

## Contents

Dangers, Warnings & Cautions	1
General Information	1
To Start the Furnace	2
Proper Maintenance	3
The Problem Solver	4
Regular Dealer Maintenance	5
Warranties	6-7

Carbon monoxide, fire or smoke can cause serious bodily injury, death, and/or property damage.

A variety of potential sources of carbon monoxide can be found in a building or dwelling such as gas-fired clothes dryers, gas cooking stoves, water heaters, furnaces and fireplaces.

The U.S. Consumer Product Safety Commission recommends that users of fuel-burning appliances install carbon monoxide detectors as well as fire and smoke detectors, listed by a nationally recognized agency (e.g. Underwriters Laboratories or International Approval Services), to help alert dwelling occupants of the presence of fire, smoke or unsafe levels of carbon monoxide.

#### NOTE:

**The manufacturer of your furnace does not test any detectors and makes no representations regarding any brand or type of detector.**

Installing and servicing heating equipment can be hazardous due to fuel oil and electrical components. Only trained and qualified personnel should install, repair or service heating equipment.

Untrained personnel can perform basic maintenance functions such as cleaning and replacing air filters. All other operations must be performed by trained service personnel.

Parts and controls of this furnace are unique. Should service or modification be required, be sure your servicer uses only factory authorized parts, kits, or accessories for this furnace.

If you experience a problem with the operation of your furnace, check the "Problem Solver" section of this manual before you call for a possibly unneeded service call.

# User's Information

## WARNING

### SAFETY HAZARD

**BODILY INJURY CAN RESULT FROM HIGH VOLTAGE ELECTRICAL COMPONENTS, FAST MOVING FANS, AND COMBUSTIBLE GAS. FOR PROTECTION FROM THESE INHERENT HAZARDS DURING INSTALLATION AND SERVICING, THE ELECTRICAL SUPPLY MUST BE DISCONNECTED AND THE MAIN GAS VALVE MUST BE TURNED OFF. FAILURE TO FOLLOW THIS WARNING MAY RESULT IN PERSONAL INJURY, PROPERTY DAMAGE, OR DEATH.**

### WHAT TO DO IN THE EVENT OF AN OIL LEAK:

- Do not try to operate this or any other nearby appliance.
- If present, close the manual oil shutoff valve on the fuel oil supply line.
- Immediately call a qualified heating dealer for service.
- If you cannot reach a qualified heating dealer, call the fuel oil supplier or the fire department.

**NOTICE: A qualified heating dealer MUST service the oil burner and inspect the heat exchanger in this furnace at least once a year.**

## To Start the Furnace

## WARNING

### SAFETY HAZARD

**IMPROPER INSTALLATION, ADJUSTMENT, ALTERATION, SERVICE, OR MAINTENANCE CAN CAUSE INJURY OR PROPERTY DAMAGE. REFER TO THE INSTALLATION INSTRUCTIONS PROVIDED WITH THE FURNACE AND THIS MANUAL. FOR ASSISTANCE OR ADDITIONAL INFORMATION CONSULT A QUALIFIED INSTALLER, SERVICE AGENCY, OR THE GAS SUPPLIER. FAILURE TO FOLLOW THIS WARNING MAY RESULT IN PERSONAL INJURY, PROPERTY DAMAGE, OR DEATH.**

### Lighting instructions.

Your oil furnace does not use a continuously burning pilot flame. Therefore, manually lighting your furnace is not required. Your furnace is equipped with an automatic spark ignition system that automatically lights the burner each time the thermostat signals the furnace to start.

## WARNING

### SAFETY HAZARD

**DO NOT ATTEMPT TO MANUALLY LIGHT THE FURNACE. FAILURE TO FOLLOW THIS WARNING MAY RESULT IN PERSONAL INJURY, PROPERTY DAMAGE, OR DEATH.**

### TO OPERATE THIS FURNACE:

- 1) Adjust the room thermostat to the lowest setpoint and set the operating mode, if equipped, to "OFF".
- 2) Turn off all electric power to the furnace at the disconnecting switch.
- 3) Turn the manual oil shutoff valve to the open or "ON" position.
- 4) This furnace is equipped with an electronic ignition system that automatically lights the burner. DO NOT try to light the burner by hand.
- 5) Turn on the electric power to the furnace at the disconnecting switch.
- 6) Adjust the room thermostat to the desired setpoint and set the operating mode, if equipped, to "HEAT".
- 7) If the furnace will not operate, call a qualified heating dealer for service.

### TO INTERRUPT (STOP) OPERATION OF THIS FURNACE:

- 1) Adjust the room thermostat to the lowest setpoint and set the operating mode, if equipped, to "OFF".
- 2) If service will be performed, turn off all electric power to the furnace at the disconnecting switch.
- 3) Turn the manual oil shutoff valve to the closed or "OFF" position.

### Extended Shutdown

If the furnace will be shutdown for an extended period of time:

- 1) Adjust the room thermostat to the lowest set point and set the operating mode, if equipped, to "OFF".
- 2) Open the disconnecting switch serving the furnace.
- 3) Close the manual oil shutoff valve.

## CAUTION

**If this is done during the cold weather months, provisions must be taken to prevent freeze-up of all water pipes and water receptacles.**

- 4) To promote smooth startup and nuisance free operation, fuel oil quality must be maintained at a high level. In cases where biological contamination of the fuel oil tank is evident or suspected, consider treating the fuel oil with a biocide approved for fuel oil applications. In addition, for non-low sulfur fuel oils, an antioxidant additive may be beneficial in promoting fuel stability. After adding any fuel oil treatment, completely fill the oil tank to promote mixing of the additive with the fuel.

Whenever your house is to be vacant, arrange to have someone inspect your house for proper temperature. If your furnace should fail to operate, damage could result, such as frozen water pipes.

# User's Information

## Proper Maintenance Reduces Energy Use

### Oil Supply

• If available, the use of ultra-low or low sulfur (less than 0.0015% S and 0.0015 -0.05% S, by weight, respectively), no. 2 fuel oil is highly recommended. Low sulfur fuel oil can help to significantly reduce instances of blockage and corrosion of the oil burner fuel delivery system, including the nozzle, the furnace heat exchanger, and the flue gas vent system. These benefits can appreciably decrease or eliminate service calls due to poor fuel quality. Air pollutants emitted by the furnace as well as the typical malodorous smell of oil combustion will also be reduced. Consult your fuel oil supplier about the availability of low-sulfur, fuel oil.

• DO NOT allow the fuel tank to run completely dry during the heating season. If the fuel tank runs completely dry, it may be necessary to purge the oil lines of trapped air. If necessary, contact a qualified heating dealer to bleed the oil lines and restart the burner.

• During the warmer weather, keep the tank full to prevent condensation of moisture on the inside surface of the tank. The presence of moisture in the tank supports the growth of biological fuel contaminants (bacteria, mold, fungus, yeast, etc.).

• Keep the cap on the fuel tank fill pipe tightly closed at all times to prevent the entrance of moisture, foreign matter, insects, etc. Consider adding a guard or filter to the tank vent pipe to reduce the entrance of water and foreign matter into the tank. Also, check the tank, vent, and fill pipe for cracks and leaks. Have any necessary tank repairs performed as soon as possible.

• Annually, have a bottom sample from the fuel oil tank taken for analysis. If present in excessive quantities, sludge and water should be removed. Fuel oil additives may be of benefit in helping to resolve some problems that are indicated by the analysis. In severe cases, tank cleaning may be required. Consult your fuel oil supplier for recommendations.

### A clean filter saves money.

When the furnace circulates and filters the air in your home, dust and dirt particles build up on the filter. Excessive accumulation can block the airflow, forcing the unit to work harder to maintain desired temperatures.

The harder your unit has to work, the more energy it uses. You pay more any time your system is running with a dirty filter.

## ⚠ CAUTION

### BURN HAZARD - ROTATING FAN BLADES

To avoid injury from moving parts, hot surfaces, or electrical shock, shut off the power to the furnace and allow the furnace to cool BEFORE removing any furnace access doors to service air filters.

## ⚠ CAUTION

Never operate your unit for either heating or cooling with filters removed.

Help ensure top efficiency by replacing disposable filters once a month.

### Replacing your filter.

When replacing your furnace filters, always use the same size and type as originally supplied. Filters are available from your dealer.

## ⚠ WARNING

### SAFETY HAZARD

DISCONNECT POWER TO UNIT BEFORE MOVING THE BLOWER DOOR. FAILURE TO FOLLOW THIS WARNING MAY RESULT IN PERSONAL INJURY, PROPERTY DAMAGE, OR DEATH.

### Highboy Furnace Filters

Highboy furnaces typically use a cleanable-type air filter located outside the furnace cabinet. The cleanable filter may be located in a side filter frame, mounted on the lower outside of the furnace cabinet in the cold air return duct or in a remotely mounted filter grill. Refer to Filter Table A for the correct filter size.

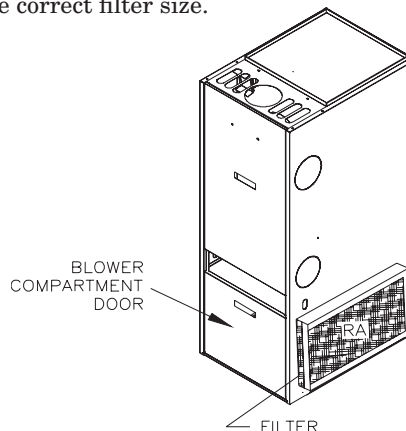

### Downflow/Horizontal Furnace Filters

Downflow/Horizontal furnaces typically use disposable filters located outside the furnace cabinet. The filters may be located remote to the furnace or in the return air duct near the furnace. The filter grille could be in a hallway, wall, or in the ceiling. Check with your dealer for the exact location, type and size of your filter and the method of changing the filters.

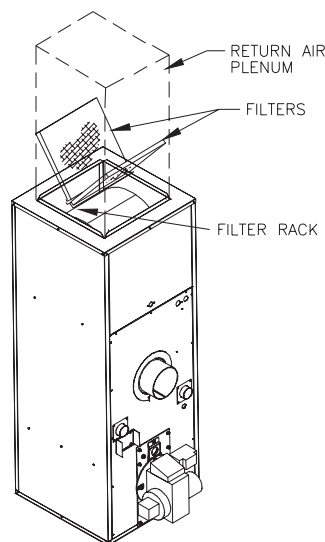

# User's Information

FILTER TABLE A

REQUIRED FILTERS	
FURNACE MODEL	FILTER QUANTITY & SIZE
THV1MO87	1 - 16" X 25" X 1"
TLF1MO87	2 - 10" X 20" X 1"
TLR1MO87	2 - 10" X 20" X 1"
TDF1MO87	NOT SUPPLIED

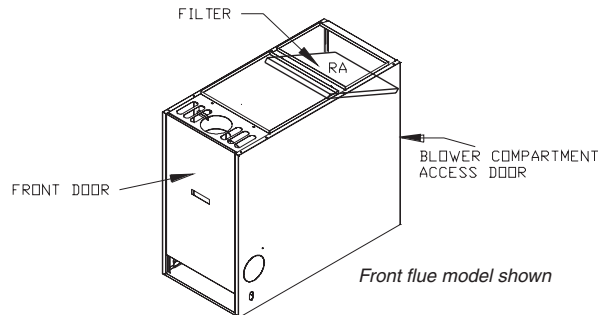

## Lowboy Furnace Filters

The Lowboy furnace typically uses a cleanable-type air filter which may be located within the furnace blower compartment or in a remotely mounted filter grill. Refer to Filter Table A for the correct filter size.

To replace filters located inside the blower compartment:

1. Turn off all power to the furnace before removing the blower door.
2. Remove blower access door and remove the soiled filter(s).
3. Replace the filter(s) in the same manner as removed making sure that the filter(s) is secured in place.
4. Replace blower access door.
5. Restore power to furnace.

## ⚠ WARNING

### SAFETY WARNING

- The area around the furnace should be kept free and clear of flammable vapors, liquids, and material, especially papers and rags.
- NEVER burn garbage or refuse in the furnace. NEVER try to ignite oil by tossing burning papers or other material into the furnace.
- This oil furnace is designed to burn No. 2 distillate fuel (home heating) oil ONLY. NEVER USE GASOLINE OR A MIXTURE OF OIL AND GASOLINE.
- DO NOT attempt to make repairs to the furnace yourself! FAILURE TO FOLLOW THIS WARNING MAY RESULT IN PERSONAL INJURY, PROPERTY DAMAGE, OR DEATH.

## The Problem Solver

A furnace is not a household appliance. It is complex and requires professional maintenance and repair.

That's why attempts at "do-it-yourself" repairs on an in-warranty unit may void the remainder of your warranty.

Other than performing the simple maintenance recommended in this manual, you should not attempt to make any adjustments to your furnace. Your dealer will be able

to take care of any questions or problems you may have. A periodic inspection of your furnace should be made by a qualified servicer at the start of each heating season.

### Keep your furnace looking like new for years.

Clean the enamel finish of your furnace with a damp cloth and a mild soap. For stubborn grease spots, use a mild household detergent. Lacquer thinner or other synthetic solvents may damage the finish.

### Save time and money. Before calling for service, check the following:

Problem	Possible Trouble	Possible Remedy
No Heating –	<ol style="list-style-type: none"> <li>1. Thermostat set incorrectly.</li> <li>2. Blown fuse or tripped circuit breaker.</li> <li>3. Defective component.</li> <li>4. Burner does not ignite.</li> <li>5. Main fuel oil valve turned off.</li> <li>6. Lockout</li> </ol>	<ol style="list-style-type: none"> <li>1. Adjust thermostat. See operating instructions.</li> <li>2. Replace or reset protective device or call for servicer.</li> <li>3. If your unit still does not operate call for Service.</li> <li>4. Call servicer.</li> <li>5. Have fuel oil supplier check.</li> <li>6. Adjust thermostat to lowest temperature Setting. - Turn thermostat OFF.               <ul style="list-style-type: none"> <li>- Press reset button on burner one time.</li> <li>- Turn thermostat ON.</li> <li>- Adjust temperature to desired setting.</li> </ul>               DO NOT ATTEMPT TO RESET BURNER MORE THAN 3 TIMES! Call for Service.             </li> </ol>
Insufficient Heating – Blower operates continuously.	<ol style="list-style-type: none"> <li>1. Dirty air filters.</li> <li>2. Blocked supply or return registers.</li> </ol>	<ol style="list-style-type: none"> <li>1. Clean or replace filters.</li> <li>2. Make sure registers are open and No obstacles blocking off the air.</li> </ol>
Unusual Noise		Call your servicer

# User's Information

## Regular Dealer Maintenance

### 1. GENERAL INSPECTION –

During startup and regular annual maintenance, a heating dealer should inspect the furnace installation for the following items:

- The exterior of the furnace should be inspected for signs of excessive heat such as discoloration of materials and damage from rust or corrosion.
  - Confirm the base or frame supporting the furnace is level and in sound condition.
  - Signs of excessive rust, corrosion pitting, and holes.
  - Signs of condensation or moisture leakage (sometimes indicated by soot or condensate streaks).
  - Evidence of structural damage, and loose or disconnected piping joints.
  - Free movement of the vane of the barometric damper without binding or interference. If any problems are evident, make repairs immediately. Do not operate the furnace until repairs are made.
  - The furnace flue pipe, vent connector, barometric damper, and chimney should be inspected for:
    - a. All flue product carrying areas external to the furnace (i.e. chimney, vent connector) are clear and free of obstruction.
    - b. The vent connector is in place, slopes upward and is physically sound without holes or excessive corrosion.
    - c. The return air duct connection(s) is physically sound, is sealed to the furnace and terminates outside the space containing the furnace.
    - d. The physical support of the furnace should be sound without sagging, cracks, gaps, etc., around the base so as to provide a seal between the support and the base.
    - e. There are no obvious signs of deterioration of the furnace.
2. BLOWERS – The blower size and speed determine the air volume delivered by the furnace. The blower motor bearings are factory lubricated and under normal operating conditions do not require servicing. Annual cleaning of the blower wheel and housing is recommended for maximum air output, and this must be performed only by a qualified servicer or service agency.
3. BURNER – Burner Compartment: On the highboy and lowboy furnace models, the burner compartment can be inspected by removing the front door of the furnace. Look for signs of excessive heat, such as discoloration of components, damage to material from rust or corrosion, soot or carbon build-up, and evidence of fuel oil leakage.
4. HEAT EXCHANGER/FLUE PIPE – These items must be inspected for signs of corrosion, and/or deterioration at the beginning of each heating season by a qualified service technician and cleaned annually for best operation.

### WARNING

#### SAFETY WARNING

Failure to follow these instructions may result in fire or explosion causing property damage, personal injury, or loss of life.

5. CIRCUIT PROTECTION – If blower or oil burner fail to operate, the cause could be the circuit breaker or a loose or blown fuse. Replace fuse or reset circuit breaker.
6. OPERATION – Your warm air furnace should not be operated in a corrosive atmosphere. Paint solvents, cleaning chemicals, spray propellants, and bleaches should not be used in the vicinity of the furnace during normal operation.
7. CONDENSATE DRAINS – If you have a cooling coil installed with your furnace, condensate drains should be checked and cleaned periodically to assure that condensate can drain freely from coil to drain. If condensate cannot drain freely water damage could occur.

#### Never stop the cooling system by shutting off the main power.

If the main power to your air conditioner is ever disconnected for more than three hours, turn off the thermostat. Then wait for at least three more hours after the power has been restored before turning the thermostat back on. Failure to follow this procedure could result in damage to your air conditioning system.

#### NOTICE: A qualified heating dealer MUST service the oil burner and inspect the heat exchanger in this furnace at least once a year.

To successfully service this oil furnace, the following recently (within the last year) calibrated instruments must be available.

- Smoke spot test kit with Bacharach-type oil burner smoke scale
- Carbon dioxide (CO<sub>2</sub>) and carbon monoxide (CO) test kit or analyzer
- Flue gas temperature measuring instrument
- Draft gauge, capable of measuring 0.01 to 0.25 in. W.G. draft (Draft is the pressure differential between the static pressure measured in the vent pipe, or just above the combustion chamber, and the indoor atmospheric pressure. Under normal operating conditions, it will have a **negative** value, i.e. the pressure in the combustion chamber and the vent system are less than room air pressure.)
- Multimeter (analog or digital type)
- Oil pressure gauge, capable of measuring at least 0 to 200 PSIG
- Burner electrode and nozzle setting gauge

Be familiar with the correct operation of these instruments as well as how to adjust the oil burner settings (refer to burner manufacturer's literature).

### WARNING

#### CARBON MONOXIDE POISONING HAZARD

Failure to follow the installation and operation instructions for the venting system's operation could result in carbon monoxide poisoning or death.

# User's Information

## **Base Limited Warranty Non-Variable Speed Oil Furnace THV, TLF, TLR, and TDF (Parts Only) Models Less Than 20 Tons for Residential Use\***

This limited warranty is provided by the manufacturer to the original purchaser and to any succeeding owner of the real property to which the oil furnace is originally affixed, and applies to products purchased and retained for use within the U.S.A. and Canada.

Beginning on January 1, 2010, R-22 refrigerant will no longer be used as a manufacturer-installed refrigerant as required by federal regulation. Following this date, depending on the availability of any remaining R-22 equipment, indoor model replacements may require that the entire system be R-410A compatible. Outdoor system components and possibly connecting line sets would need to be replaced in order to be compatible with indoor units containing R-410A refrigerant. Expenses associated with replacing system components that are not R-410A compatible will not be covered by the terms and conditions of the limited warranty.

The limited warranty period begins when installation is complete and the oil furnace start-up procedure has been properly completed, verified by installer's invoice or similar document. If installation completion and start-up date cannot be verified by installer's invoice or similar document, this limited warranty coverage begins six (6) months after the date of manufacture based on the oil furnace serial number.

If any functional part of your oil furnace fails because of a manufacturing defect within five (5) years from the date the limited warranty period begins, Warrantor will furnish without charge the required replacement part. Any other costs, such as local transportation, related service labor, diagnosis calls, refrigerant and related items are not included.

In addition, if the heat exchanger fails because of a manufacturing defect within the sixth through twentieth year from the date the limited warranty period begins, Warrantor WILL AT ITS OPTION provide either a heat exchanger without charge, or allow a credit in the amount of the then current wholesale price of an equivalent heat exchanger toward the purchase price of a comparable heating unit. Any other costs, such as local transportation, related service labor, diagnosis calls, refrigerant and related items are not included.

This limited warranty does not apply if the oil furnace was purchased direct (i.e. from internet websites or auctions) on an uninstalled basis. Additionally, this limited warranty will not apply unless the oil furnace is: (1) installed by a licensed or qualified HVAC technician, (2) applied and installed in accordance with the manufacturer's recommendations in its Installer's Guide, and (3) in compliance with all industry standards, national, state, and local codes.

This limited warranty does not cover failure of your furnace if it is damaged while in your possession; including, but not limited to (1) damage caused by unreasonable use, (2) damage from failure to properly maintain as set forth in the Use and Care manual, (3) damage that is not considered a manufacturing defect, such as acts of God, malfunctions or failures resulting from fire, water, storms, lightning, earthquake, theft, riot, misuse, abuse, increased utility usage costs, or (4) performance problems due to improper selection/equipment match, installation or application.

This limited warranty applies to product installed on or after 5/1/2009.

Registered Limited Warranty Option

If registered within 60 days of the original installation date, the limited warranty terms will be lengthened\*\* as follows: heat exchanger – lifetime.

\*\*Registered Limited Warranty lengthened terms are non-transferable and do not apply to income property.

To register, go to the manufacturer's website or contact your dealer.

**THE LIMITED WARRANTY AND LIABILITY SET FORTH HEREIN ARE IN LIEU OF ALL OTHER WARRANTIES AND LIABILITIES, WHETHER IN CONTRACT OR IN NEGLIGENCE, EXPRESS OR IMPLIED, IN LAW OR IN FACT, INCLUDING BUT NOT SPECIFICALLY LIMITED TO IMPLIED WARRANTIES OF MERCHANTABILITY AND FITNESS FOR PARTICULAR USE, AND IN NO EVENT SHALL WARRANTOR BE LIABLE FOR ANY INCIDENTAL OR CONSEQUENTIAL DAMAGES.**

Some states and provinces do not allow limitations on how long an implied limited warranty lasts or do not allow the exclusion or limitation of incidental or conse-quential damages, so the above limitation or exclusion may not apply to you. This limited warranty gives you specific legal rights, and you may also have other rights which vary by jurisdiction.

Parts will be provided by our factory organization through an authorized service organization in your area listed in the yellow pages.

If you wish further help or information concerning this limited warranty, contact:

Residential Systems  
6200 Troup Highway, Tyler, TX 75707  
Attention: Customer Relations

TW-1057-1409

\* This limited warranty is for residential usage of this equipment and not applicable when this equipment is used for a commercial application. A commercial use is any application where the end purchaser uses the product for other than personal, family or household purposes.

Extended warranties are available from the manufacturer through your dealer. The limited warranty is backed by the manufacturer and any representations made about extending the limited warranty would be backed by the manufacturer if and only if an extended warranty agreement was received *from the manufacturer*.

## Limited Warranty High Efficiency Oil Furnace THV, TLR, TLF and TDF (Parts Only)

### Models Less Than 20 Tons for Commercial Use\*

This limited warranty is extended by the manufacturer to the original purchaser and to any succeeding owner of the real property to which the oil furnace is originally affixed and applies to products purchased and retained for use within the U.S.A. and Canada. There is no warranty against corrosion, erosion, or deterioration.

Beginning on January 1, 2010, R-22 refrigerant will no longer be used as a manufacturer-installed refrigerant as required by federal regulation. Following this date, depending on the availability of any remaining R-22 equipment, indoor model replacements may require that the entire system be R-410A compatible. Outdoor system components and possibly connecting line sets would need to be replaced in order to be compatible with indoor units containing R-410A refrigerant. Expenses associated with replacing system components that are not R-410A compatible will not be covered by the terms and conditions of the limited warranty.

The limited warranty period begins when installation is complete and the oil furnace start-up procedure has been properly completed, verified by installer's invoice or similar document. If installation completion and start-up date cannot be verified by installer's invoice or similar document, limited warranty coverage begins six (6) months after the date of manufacture based on the oil furnace serial number.

If any part of your oil furnace fails because of a manufacturing defect within one (1) year from the date the limited warranty period begins, Warrantor will furnish without charge the required replacement part.

In addition, if the steel heat exchanger fails because of a manufacturing defect within the second through twentieth year from the date the limited warranty period begins, Warrantor shall furnish without charge a replacement heat exchanger. Warrantor's obligations and liabilities under this warranty are limited to furnishing F.O.B. Warrantor factory or warehouse replacement parts for Warrantor's products covered under this warranty. No liability shall attach to Warrantor until products have been paid for and then liability shall be limited solely to the purchase price of the equipment under warranty shown to be defective.

This limited warranty does not apply if the oil furnace was purchased direct (i.e. from internet websites or auctions) on an uninstalled basis. Additionally, this limited warranty will not apply unless the oil furnace is: (1) installed by a licensed or qualified HVAC technician, (2) applied and installed in accordance with the manufacturer's recommendations in its Installer's Guide, and (3) in compliance with all industry standards, national, state, and local codes.

This limited warranty does not cover your oil furnace if it is damaged while in your possession; including, but not limited to (1) damage caused by unreasonable use of the oil furnace, (2) damage from failure to properly maintain the oil furnace as set forth in the Use and Care manual (refer to "Proper Maintenance" section), (3) damage that is not considered a manufacturing defect, such as acts of God, malfunctions or failures resulting from fire, water, storms, lightning, earthquake, theft, riot, misuse, abuse, increased utility usage costs, or (4) performance problems due to improper selection / equipment match-up, installation, or application.

**THE LIMITED WARRANTY AND LIABILITY SET FORTH HEREIN ARE IN LIEU OF ALL OTHER WARRANTIES AND LIABILITIES, WHETHER IN CONTRACT OR IN NEGLIGENCE, EXPRESSED OR IMPLIED, IN LAW OF IN FACT, INCLUDING IMPLIED WARRANTIES OF MERCHANTABILITY AND FITNESS FOR PARTICULAR USE, AND IN NO EVENT SHALL WARRANTOR BE LIABLE FOR ANY INCIDENTAL OR CONSEQUENTIAL DAMAGES.**

Some states do not allow limitations on how long an implied limited warranty lasts or do not allow the exclusion or limitation of incidental or consequential damages, so the above limitation or exclusion may not apply to you. This limited warranty gives you specific legal rights, and you may also have other rights which vary from state to state.

Parts will be provided by our factory organization through an authorized service organization in your area listed in the yellow pages. If you wish further help or information concerning this limited warranty, contact:

Residential Systems  
6200 Troup Highway, Tyler, TX 75707  
Attention: Consumer Relations

Or visit our website: [www.trane.com/residential](http://www.trane.com/residential)

TW-1035-3308

\* This warranty is for commercial usage of said equipment and not applicable when the equipment is used for a residential application. Commercial use is any application where the end purchaser uses the product for other than personal, family or household purposes.

Extended warranties are available from the manufacturer through your dealer. The limited warranty is backed by the manufacturer and any representations made about extending the limited warranty would be backed by the manufacturer if and only if an extended warranty agreement was received from the manufacturer.

# Important Product Information

Registering your products helps provide you with one of the strongest manufacturer limited warranties available. To register, go to the manufacturer's website or contact your dealer. You will need the serial number, model number, and installation date for each product being registered. Your dealer may have included these on your invoice or can provide a list for you to use. Please take a few moments to record the following information to ensure your product registration process is quick and easy:

Furnace Serial Number \_\_\_\_\_

Furnace Model Number \_\_\_\_\_

Indoor Coil Serial Number \_\_\_\_\_

Indoor Coil Model Number \_\_\_\_\_

Date of Installation \_\_\_\_\_

Dealer \_\_\_\_\_

## Service Information

Call your installing dealer if the unit is inoperative. Before you call, always check the following to be sure service is required:

- a. Be sure the main switch that supplies power to the unit is in the ON position.
- b. Replace any burned-out fuses or reset circuit breakers.
- c. Be sure the thermostat is properly set.

Service Phone \_\_\_\_\_



Literature Order Number	32-5037-04
File Number	32-5037-04
Supersedes	32-5037-03
Date	04/09

**Trane**  
6200 Troup Highway  
Tyler, TX 75707

For more information contact  
your local dealer (distributor)

Since the manufacturer has a policy of continuous product and product data improvement, it reserves the right to change design and specifications without notice.